



UNIVERSITY OF CAMBRIDGE INTERNATIONAL EXAMINATIONS  
International General Certificate of Secondary Education

CANDIDATE  
NAME

CENTRE  
NUMBER

--	--	--	--	--

CANDIDATE  
NUMBER

--	--	--	--

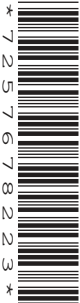

**PHYSICS**

**0625/52**

Paper 5 Practical Test

**May/June 2010**

**1 hour 15 minutes**

Candidates answer on the Question Paper

Additional Materials: As listed in the Confidential Instructions

**READ THESE INSTRUCTIONS FIRST**

Write your Centre number, candidate number and name in the spaces at the top of the page.

Write in dark blue or black pen.

You may use a pencil for any diagrams, graphs or rough working.

Do not use staples, paper clips, highlighters, glue or correction fluid.

**DO NOT WRITE IN ANY BARCODES.**

Answer **all** questions.

At the end of the examination, fasten all your work securely together.

The number of marks is given in brackets [ ] at the end of each question or part question.

For Examiner's Use	
<b>1</b>	
<b>2</b>	
<b>3</b>	
<b>4</b>	
<b>Total</b>	

This document consists of **9** printed pages and **3** blank pages.



- 1 In this experiment, you are to determine the mass of a load using a balancing method.

Carry out the following instructions referring to Fig. 1.1.

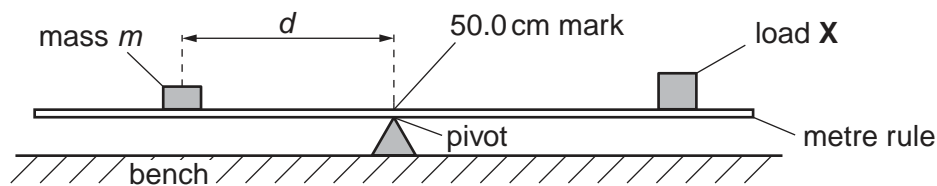

**Fig. 1.1**

The load **X** has been taped to the metre rule so that its centre is exactly over the 90.0 cm mark. Do not move this load.

- (a) Place a mass of 40 g on the rule and adjust its position so that the rule is as near as possible to being balanced with the 50.0 cm mark exactly over the pivot as shown in Fig. 1.1.
- (i) Record in Table 1.1 the distance  $d$  from the centre of the 40 g mass to the 50.0 cm mark on the rule.
  - (ii) Repeat step (i) using masses of 50 g, 60 g, 70 g and 80 g to obtain a total of five sets of readings. Record the readings in the table.
  - (iii) For each value of  $d$  calculate  $\frac{1}{d}$  and enter the values in the table.

**Table 1.1**

$m/g$	$d/cm$	$\frac{1}{d} / \frac{1}{cm}$
40		
50		
60		
70		
80		

[2]

- (b) Plot a graph of  $m/g$  ( $y$ -axis) against  $\frac{1}{d} / \frac{1}{\text{cm}}$  ( $x$ -axis).

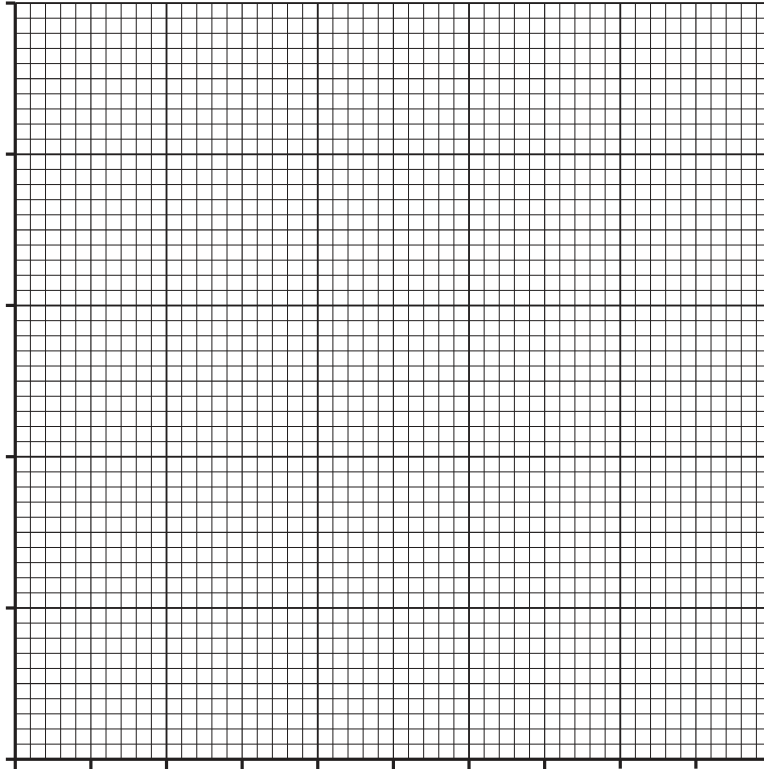

[4]

- (c) Determine the gradient  $G$  of the graph. Show clearly on the graph how you obtained the necessary information.

$$G = \dots\dots\dots [2]$$

- (d) Determine the mass  $\mu$  of the load **X** using the equation  $\mu = \frac{G}{k}$  where  $k = 40.0 \text{ cm}$ .

$$\mu = \dots\dots\dots [2]$$

2 In this experiment you will investigate the rate of cooling of water in different containers.

Carry out the following instructions referring to Fig. 2.1.

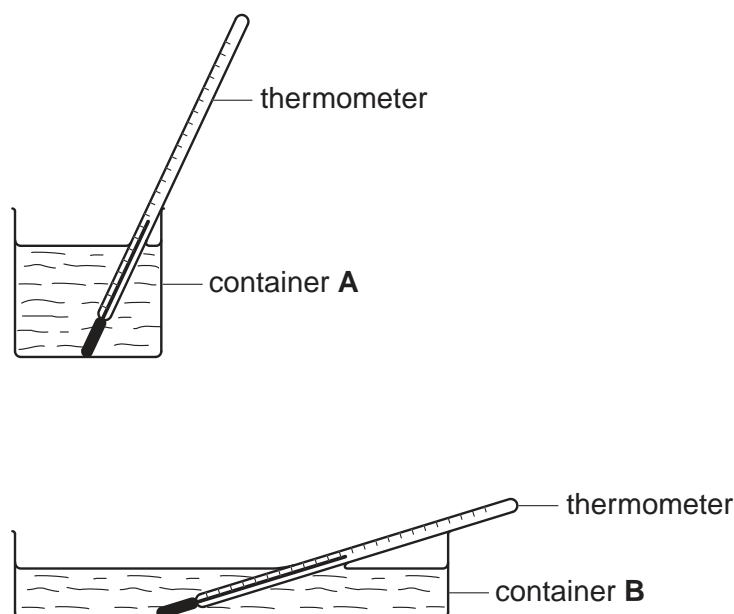

**Fig. 2.1**

- (a) (i) Pour approximately  $200\text{ cm}^3$  of hot water into container **A**.
- (ii) Place the thermometer in container **A**.
- (iii) Record in Table 2.1 the temperature of the water at 30 s intervals from  $t = 0\text{ s}$  until you have a total of seven values up to time  $t = 180\text{ s}$ .
- (iv) Place the thermometer in container **B**.
- (v) Pour hot water into container **B** until there is sufficient at least to cover the thermometer bulb.
- (vi) Repeat step (iii).
- (vii) Complete the column headings in the table.

Table 2.1

	(Container A)	(Container B)
$t/$	$\theta/$	$\theta/$

[5]

- (b) Calculate the temperature change of the water in each container over the period of 180 s.

Container A temperature change = .....

Container B temperature change = ..... [1]

- (c) State which container, A or B has the greater rate of cooling. Justify your answer by reference to your readings.

Statement .....

Justification .....

.....

..... [2]

- (d) To make a fair comparison between the rates of cooling of the hot water in the two containers it is important to control other experimental conditions. Suggest two conditions that should be controlled in this experiment.

1 .....

2 ..... [2]

- 3 In this experiment, you are to determine the resistances of lamps in different circuit arrangements. Carry out the following instructions, referring to Fig. 3.1.

The circuit shown in Fig. 3.1 has been set up for you. This is Circuit 1.

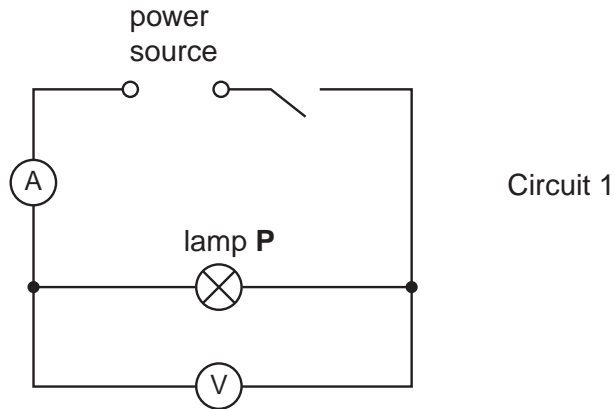

**Fig. 3.1**

- (a) Switch on. Measure and record in Table 3.1 the current  $I$  in the circuit and the p.d.  $V$  across lamp **P**. Switch off.
- (b) Calculate the resistance  $R$  of lamp **P** using the equation  $R = \frac{V}{I}$ .  
Record this value of  $R$  in the table.
- (c) Replace lamp **P** with lamp **Q**. This is Circuit 2 (not shown). Repeat steps (a) and (b).
- (d) Return lamp **P** to the circuit so that lamps **P** and **Q** are in parallel with each other. This is Circuit 3. Repeat steps (a) and (b).

**Table 3.1**

	$V/$	$I/$	$R/$
Circuit 1			
Circuit 2			
Circuit 3			

[5]

- (e) Complete the column headings in the table.

(f) Draw a diagram of Circuit 3 using standard circuit symbols.

[3]

(g) A student suggests that the resistance of lamp **P** added to the resistance of lamp **Q** should be equal to the combined resistance of the two lamps when arranged in parallel in Circuit 3. State whether or not your results support this suggestion and justify your answer with reference to your experimental results.

Statement .....

Justification .....

.....

.....

..... [2]

- 4 In this experiment you will investigate refraction and reflection of light in a transparent block.

Carry out the following instructions referring to Fig. 4.1.

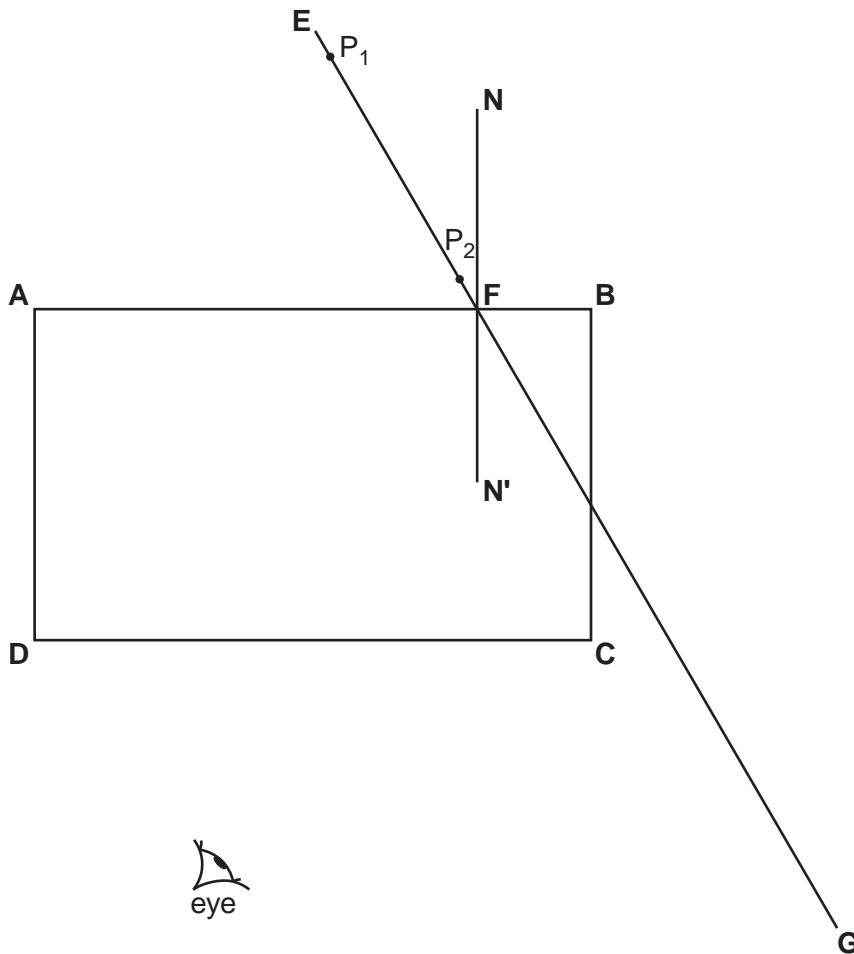

Fig. 4.1

- Place the transparent block, largest face down, on the ray-trace sheet supplied. The block should be approximately in the middle of the paper. Draw the outline of the block **ABCD**.
- Remove the block and draw the normal **NN'** to side **AB** so that the normal is 2.0 cm from **B**. Label the point **F** where **NN'** crosses **AB**.
- Draw the line **EF** at an angle of incidence  $i = 30^\circ$  to the normal. Continue the line so that it crosses **BC** and extends about 5 cm beyond **BC** as shown in Fig. 4.1. Label the end of the line **G**.
- Place the paper on the pin board.
- Push two pins  $P_1$  and  $P_2$  into line **EF** as indicated in Fig. 4.1.
- Replace the block and observe the images of  $P_1$  and  $P_2$  through side **CD** of the block from the direction indicated by the eye in Fig. 4.1 so that the images of  $P_1$  and  $P_2$  appear one behind the other.  
Push two pins  $P_3$  and  $P_4$  into the surface, between your eye and the block, so that  $P_3$ ,  $P_4$  and the images of  $P_1$  and  $P_2$ , seen through the block, appear in line.  
Mark the positions of  $P_1$ ,  $P_2$ ,  $P_3$  and  $P_4$ . Remove the block.



- (g) Draw a line joining the positions of  $P_3$  and  $P_4$ . Continue the line so that it crosses **CD** and extends beyond **BC** to cross line **EFG**. Label the end of the line **H**.
- (h) Remove the pins from the ray trace sheet. Measure the smaller angle  $\theta$  between line **EFG** and the line joining the positions of  $P_3$ ,  $P_4$  and **H**.

$\theta =$  ..... [1]

- (i) Calculate the difference  $(\theta - 2i)$ .

$(\theta - 2i) =$  ..... [1]

- (j) Repeat steps (c) to (i) using an angle of incidence  $i = 40^\circ$  to the normal.

$\theta =$  .....

$(\theta - 2i) =$  ..... [1]

- (k) Theory suggests that  $\theta = 2i$ . State whether your result supports the theory and justify your answer by reference to your results.

Statement .....

Justification .....

.....

..... [2]

**Tie your ray trace sheet into this Booklet between pages 8 and 9.** [5]





**BLANK PAGE**

---

Permission to reproduce items where third-party owned material protected by copyright is included has been sought and cleared where possible. Every reasonable effort has been made by the publisher (UCLES) to trace copyright holders, but if any items requiring clearance have unwittingly been included, the publisher will be pleased to make amends at the earliest possible opportunity.

University of Cambridge International Examinations is part of the Cambridge Assessment Group. Cambridge Assessment is the brand name of University of Cambridge Local Examinations Syndicate (UCLES), which is itself a department of the University of Cambridge.